

Incremental 70-mm-Dia. Rotary Encoder

M70SA

General purpose encoder with external Diameter of 70mm

- Incremental model
- External diameter of 70mm
- Resolution up to 5400 ppr.
- Various output type
- Solid shaft with Dia at 8 mm



Ordering Information

M70SA -

1 2 3 4 5 6 7

Section 1: Basic model name

M70SA: 70mm encoder

Section 2: Shaft Size

8: Solid shaft with Dia at 8 mm

Section 3: Resolution

10: 10 ppr
20: 20 ppr

40 50 60 80 100 120 125 150
200 225 240 250 256 300 360 400 450
480 500 512 600 625 720 750 800 900
1000 1024 1080 1200...up to 5400

Not indicated resolution is customizable

Section 4: Output phase

3: A B Z
6: A \bar{A} B \bar{B} Z \bar{Z}

Section 5: Output type

C: Complementary (also known as totem pole)
N: NPN Open collector
P: PNP Open collector
V: Voltage output
L: Line driver (Power source 5VDC ONLY)
T: Push-Pull (HTL with inverted signal)

Section 6: Power Supply

8: 8-30 VDC (+/- 5%)
5: 5 VDC (+/- 5%)

Section 7: Cable outgoing type

G: Side entry cable
E: Rear entry cable
X: Side entry plug
Y: Rear entry plug
▲ Standard cable length is 2M

Ratings and Specifications

- Power supply:** 5 VDC / 8-30 VDC
Resolution: 5-5400 ppr
Current consumption: 100mA (Load disconnected)
Load current: 50mA maximum per channel 20mA maximum per channel (Line driver output)
Output type: NPN/PNP open collector/Complementary/Voltage/Line Driver/ Push-Pull (HTL with reverse signal)
Frequency: 100K HZ Frequency=RPM*Resolution/60
Maximum permissible speed: 6000 rpm
Shaft loading radial: 25N
Shaft loading thrust: 35N
Weight: Approx 0.38KG
Protection level: IP50
Temperature: operation(-10°C~+70°C), storage(-30°C~+85°C)
Vibration resistance: 50m/s, 10-200 HZ, 1 mm double amplitude for 2 hours each in X, Y, and Z directions
Shock resistance: 980m/s, 6m/s 2 times each in X, Y, and Z directions
Starting torque: 5 x 10⁻³ N.m Maximum

▲ Cable with connector are available on request

Output circuits and wave forms

Wave forms

Complementary/Open collector(NPN&PNP)/Voltage output

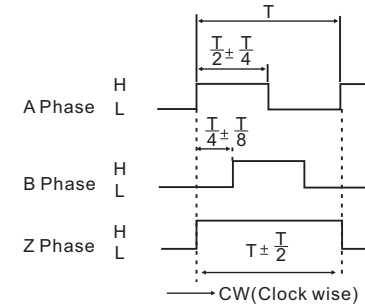

CW: As viewed from the shaft

Line Driver(RS422)/Push-pull(HTL with reverse signal)

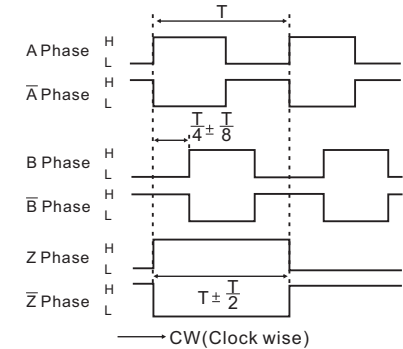

Output circuits

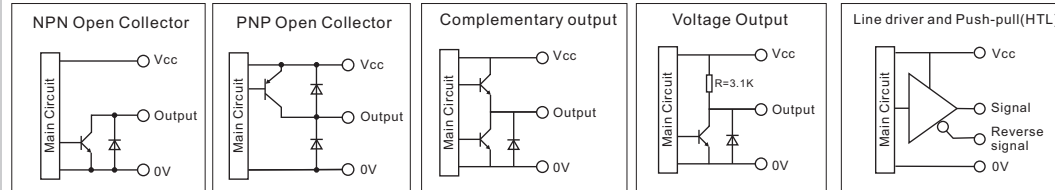

Wiring Details

Complementary/Open collector(NPN/PNP)/Voltage output

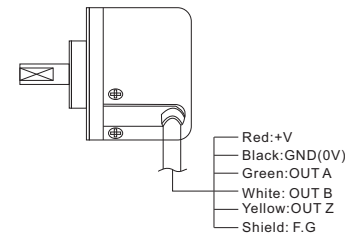

Line Driver/ Push-pull(HTL with reverse signal)

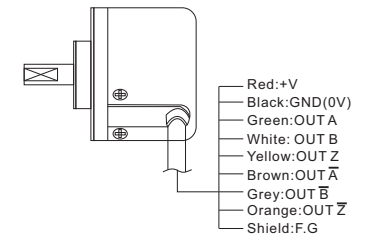

Mounting and Dimensions

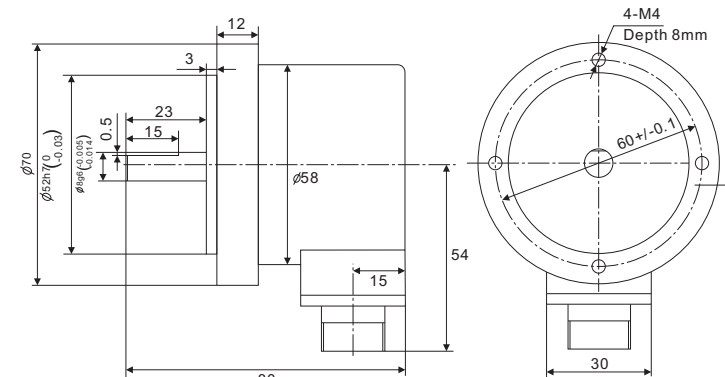

M70SA